

INSTRUCTION MANUAL

IMPORTANT! Read these instructions before you use your new 044 HD Key Machine.
Ensure that all safety recommendations are followed!
See page 3 for instructions.



PERFORMANCE
Series

This manual applies specifically to the 044 HD Performance Series key machine. It properly identifies your model and assures you will receive correct parts, if and when you require replacement parts. Retain this manual in a safe place. If ownership of this machine is transferred, this service manual should accompany the machine.

When seeking service information about this machine, refer to Model No. 044 HD and the part number desired (see pages 6 to 8). Note that many parts are not interchangeable with other KABA ILCO machines.

CONTENTS

Warranty	2
Safety information	3
Introduction / unpacking	4
Operating parts (illustrated).....	5
Operating parts identification (names and part numbers) ..	5
Exploded view	6
Exploded view parts list / unpacking / test keys	8
How to duplicate keys	9
The cutting operation / replacing the cutter	12
Adjustments	13

ONE YEAR LIMITED WARRANTY

KABA ILCO warrants to the original buyer of any new model 044 HD machine that it will repair or replace, at its option, any part of any machine which proves, to the reasonable satisfaction of KABA ILCO, to have defects arising from the faulty manufacture of the machine or from defective material or components, during a period of one (1) year from the date of shipment of the machine by KABA ILCO, provided that the machine is returned by prepaid transport to KABA ILCO or to its authorized representative before the expiry of the warranty period together with a detailed description of the alleged defect(s). KABA ILCO may, at its discretion, elect to refund the purchase price allowable to the part affected, or to issue a credit if the price therefore remains unpaid.

KABA ILCO sells precision-made machines. The buyer assumes all risks, and KABA ILCO shall not be liable for any reason, if the machine has been subjected to improper installation, improper use, improper or inadequate maintenance, negligence, if any unauthorized modification or alteration is made to the machine, or in case of accident. For greater certainty, any machine not operated in accordance with KABA ILCO printed instructions or operated beyond its rated capacity shall not be covered by this or any other warranty.

Any and all warranties made by KABA ILCO on any machine, product, or component thereof shall be effective only if and for so long as the buyer complies with all payment obligations pursuant to the buyer's accepted and acknowledged order. Failure to meet such payment obligations shall void all warranties and not extend the period of time for which such machine, product or component thereof is warranted irrespective of whether or not payment is eventually made.

These warranties are in lieu of and not in addition to any other warranty of condition, expressed or implied, including without limitation merchantability, fitness for a particular purpose or latent defects. The buyer releases KABA ILCO from any liability for any reason other than a breach of its warranties hereunder.

The liability of KABA ILCO shall in no case, including negligence, exceed the purchase price of the defective machine, nor shall KABA ILCO be liable for any personal injuries, property damage or consequential damages.

Use only genuine KABA ILCO replacement parts on this machine!

Serial number : _____

IMPORTANT - Please read carefully before operating machine.

Safety begins with education, and continues with proper application. All personnel who operate your machine should read the supplied Operator's Manual for information on how to properly operate it. The likelihood of accidents and miscuts will be greatly reduced.

General safety

- Safety glasses must be worn to reduce the possibility of eye injury while operating or in the immediate vicinity of key cutting equipment.
- Always turn machine off before making adjustments or inserting or removing keys.
- Machine should be located in an area accessible only by authorized operators. Location must be such that customers and other personnel are not subject to potential injury from "flying chips".
- Do not defeat safety features built into your machine. Removal or modification of safety shields, cutter guards, and other safety devices should be strictly forbidden.
- At no time should the mechanically-driven parts of the machine be touched while it is in operation. The operator should take care to ensure that loose-fitting clothing, long hair, etc. are kept from the area of machine operation.
- Your machine has been specially designed and built for key cutting purposes only and should be operated according to the Operator's Manual. All other uses are strongly discouraged as potentially dangerous, and should not be attempted! Such use will immediately void the machine's warranty.
- Some states have specific age restriction concerning the operation of certain types of equipment. Check local and state ordinances for compliance.

Electrical safety

- (115 Volt models) Your machine is designed to operate using 120 Volt A. C. 60 Hz. electrical current. It is supplied with a three-prong power plug which should be used with a properly grounded three-prong outlet only. Do not defeat the safety purpose of the plug by modifying or using with non-grounded outlets!
- To reduce risk of fire or electrical shock, do not expose or operate machine in damp or wet locations.
- Electrical problems should be referred to qualified repair technicians. If the machine is under warranty, contact KABA ILCO at the address printed on the cover. (KABA ILCO also offers repair service for out-of-warranty machines. Contact KABA ILCO for details.)
- Always unplug the machine before removing the hood or changing the cutter wheel.

Grounding instructions

- In the event of a malfunction or breakdown, grounding provides a path of least resistance for electric current to reduce the risk of electric shock. This machine is equipped with an electric cord that has an equipment-grounding conductor and a grounding plug. The plug must be plugged into a machine outlet that is properly installed and grounded in accordance with all local codes and ordinances.
- Do not modify the plug provided - if it will not fit the outlet, have the proper outlet installed by a qualified electrician.
- Improper connection of the equipment grounding conductor can result in a risk of electric shock. The conductor with insulation that has a green outer surface (with or without yellow stripes) is the equipment-grounding conductor. If repair or replacement of the electric cord or plug is necessary, do not connect the equipment grounding conductor to a live terminal.
- Check with a qualified electrician or service personnel if the grounding instructions are not completely understood, or if in doubt as to whether the machine is properly grounded.
- Use only 3-wire extension cords that have 3-prong grounding plugs and 3-pole receptacles that accept the machine's plug.
- Repair or replace damaged or worn cords immediately.

INTRODUCTION / UNPACKING

Congratulations!

You've purchased a superior key cutting machine.

The Model 044 HD manual Performance Series key machine you've just purchased incorporates the latest improvements in design for key duplicating machines of its type.

This machine features exclusive four-way vise jaws designed to accommodate virtually any standard cylinder key without the need for adapters.

Even double-sided automotive keys can be duplicated with ease; the four-way jaws include stations ideally suited to gripping these keys and is capable of gripping them in the groove or milling for enhanced clamping performance when necessary.

Accurate, easy to operate and maintain, the model 044 HD delivers excellent performance at an economical price!

Unpacking instructions

Your 044 HD key machine has been shipped to you in a sturdy, specially cushioned container to prevent the possibility of damage during handling and shipment. Once the machine is removed from the carton, it should be set up on a level workbench and wiped free of all rustproof-

ing oil. The machine is adjusted at the factory and test keys have been cut on it, but it is recommended that you check the adjustments to make sure they have not slipped or shifted during transit (see page 13 "Adjusting for depth of cut").

Safety

The 044 HD has been engineered to duplicate cylinder (paracentric) keys. It is not intended or designed for any other purpose. The machine operator assumes all liability when using this machine in a manner inconsistent with its stated design purpose. Refer to page 3 for complete safety information before operating the machine.

KABA ILCO **strongly recommends** the use of protective eye glasses or goggles when operating this machine, or

when in the vicinity of the machine while it is being operated. Protective eye wear prevents injuries! The machine should be turned off before loading or unloading keys.

When the key machine is operating, be careful not to contact the vise jaw or carriage against the cutting wheel as this will cause damage to the cutter, jaw, or carriage.

CAUTION! DO NOT DESTROY OR DISCARD THIS SPECIAL SHIPPING CARTON. STORE IT CAREFULLY IN A SAFE PLACE. THIS CARTON SHOULD BE USED WHENEVER THE MACHINE IS MOVED OR SHIPPED.

OPERATING PARTS

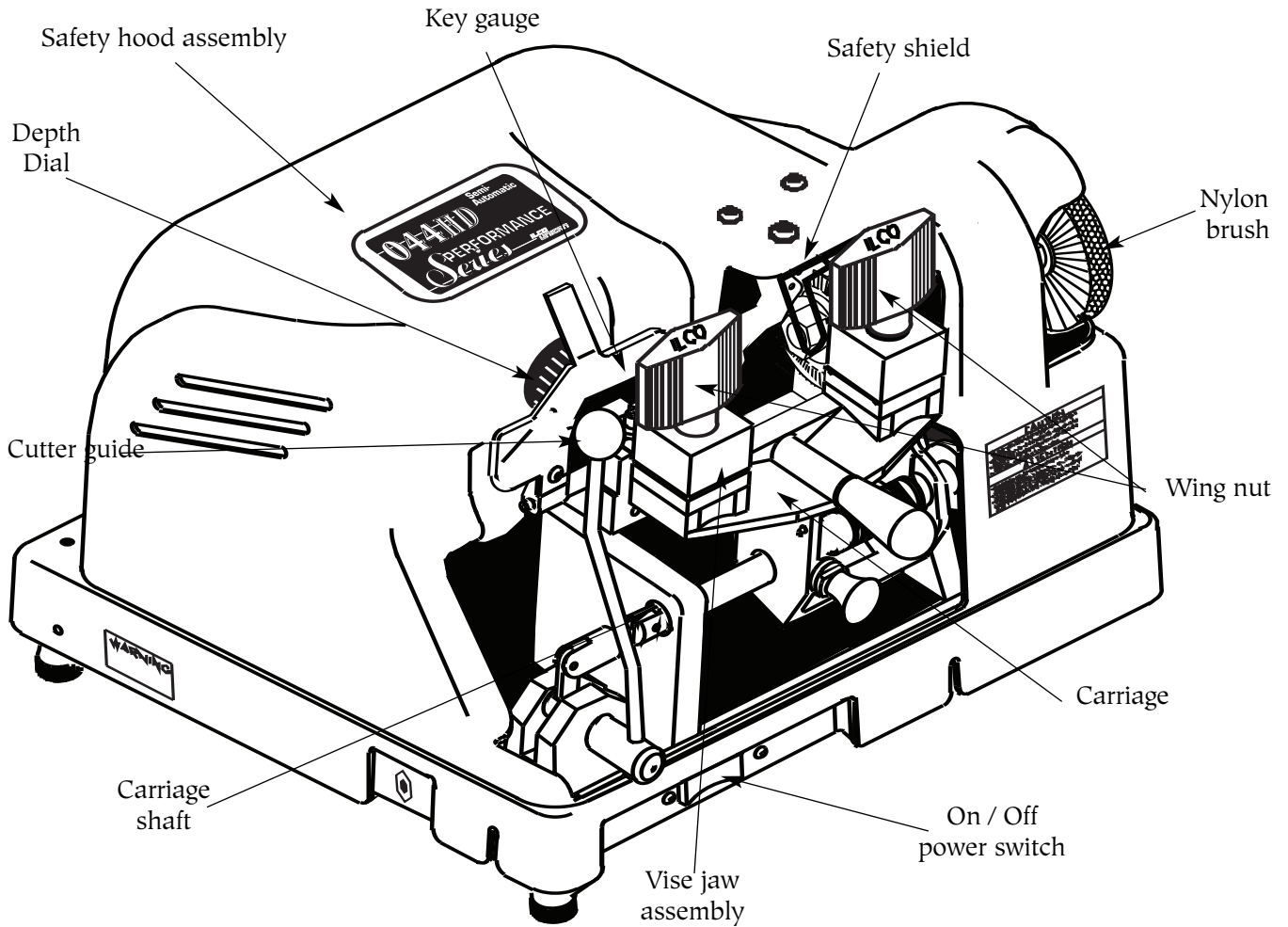

Operating parts identification

Part no.	Identification
024B-1	Carriage
025-3X	Vise jaw assembly
025-8	Wing nut
045-23	Carriage shaft
P-CU20	P-CU20 cutter
814-00-51	Nylon brush
045-49	Cutter guide (stylus)
045-55A	Adjusting screw
040-56	Key gauge
025-62A	On/Off switch
045-86X	Safety hood assembly
045-87	Safety shield

EXPLODED VIEW

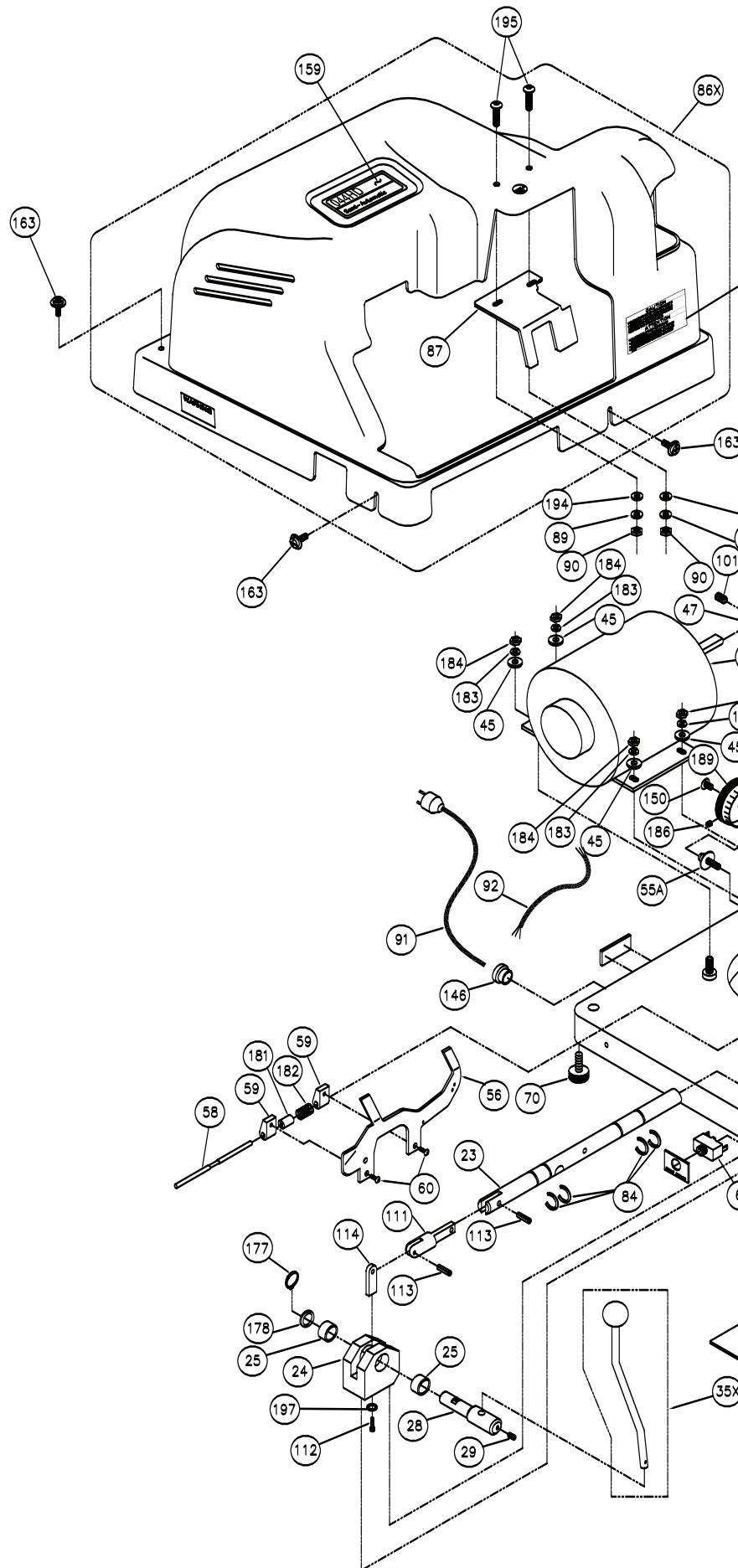

EXPLODED VIEW

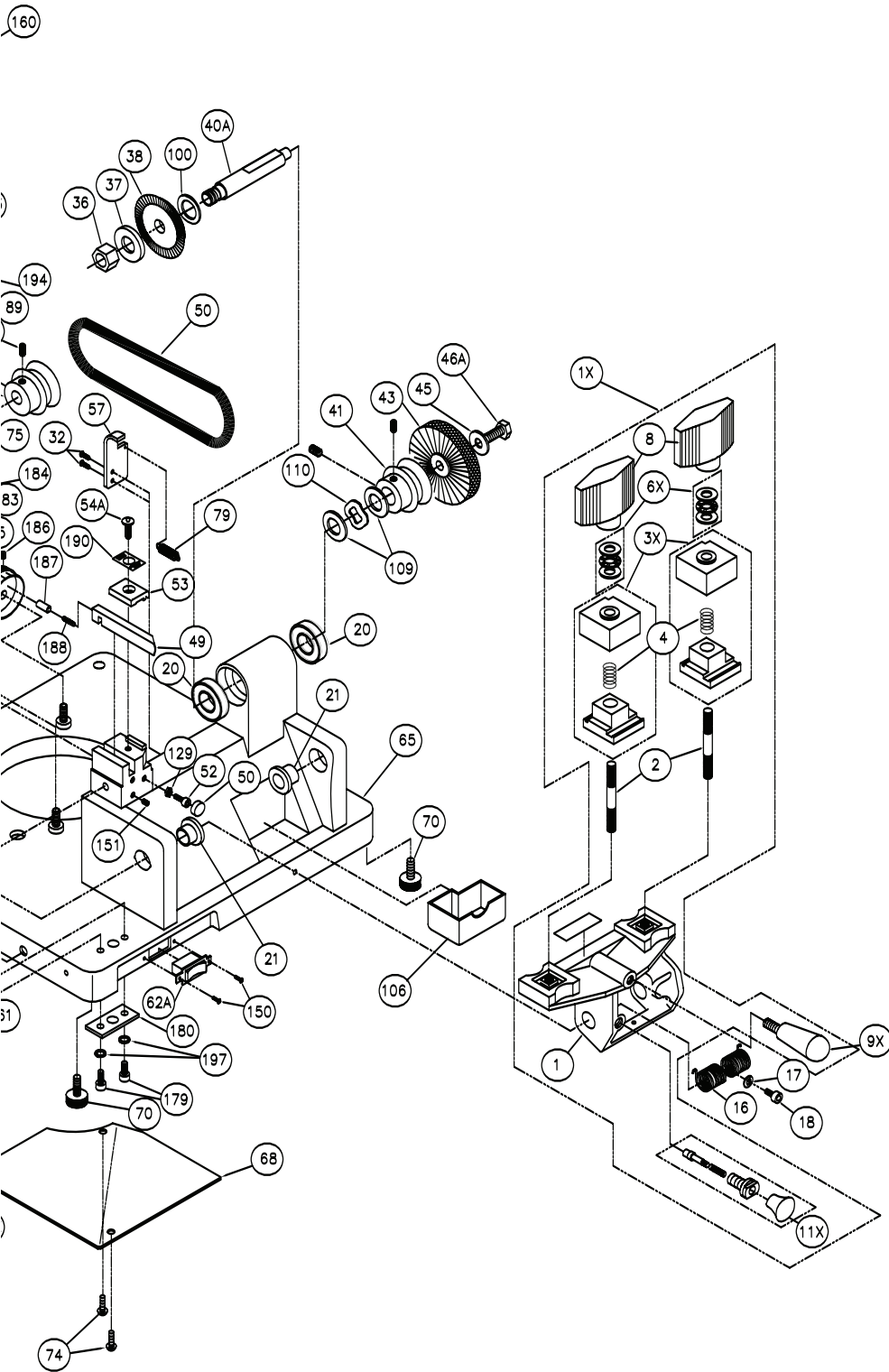

EXPLODED VIEW PARTS LIST

Refer to pages 6-7 for illustration

Ref.	Part no.	Description	Ref.	Part no.	Description
1	044HD-1	Carriage	79	024B-79	Key gauge spring
1X	044HD-1X	Carriage assembly	84	024B-84	Clip
2	025-2	Carriage stud	86X	044HD-86X	Safety hood assembly
3X	045HD-3X	Vise jaw assembly (Super Jaw 3)	87	044HD-87	Safety shield
4	025-4	Vise jaw spring	89	045-89	#10 Lockwasher
6X	025-6X	Thrust bearing set	90	025-90	Nut, #10-32
8	025-8	Wing nut	91	024B-91	Power cord
9X	040-9X	Carriage handle	92	024B-92	3 wire motor cable
20	040HD-20	Cutter shaft bearings	100	040HD-100	Cutter spacer; right
21	025-21	Carriage shaft bushing	101	025-101	Motor pulley set screw
23	044HD-23	Carriage shaft	106	040-106	Chip tray
32	024B-32	Button head. screw, 10-24 x 3/8"	109	025-109	Bearing washer
36	025-36	Cutter nut, N-4	110	025-110	Wave washer
37	025-37	Cutter spacer; left	129	040-129	Locking nut (8-32)
38	P-CU20	P-CU20 cutter	146	040-146	Power cord strain relief
40	040HD-40	Cutter shaft	150	040-150	Switch screw (6-32 x 1/4")
41	040HD-41	Cutter shaft pulley (2")	151	040-151	Set screw (8-32 x 3/8")
43	814-00-51	Nylon brush	160	025-160	Caution label
45	024-45	Brush bolt washer, 5/16"	163	045-163	Hood Screw
46A	025-46A	Hex head screw, 5/16-18 x 3/4"	171	025-171	Cutter pulley set screw, 3/8" -18
47	025-47	Motor pulley 2" - 3L	181	024B-181	Key Gauge Spacer - Left
48	040HD-48	V-Belt, 3L160	182	024B-182	Key Gauge Spacer - Right
49	045-49	Cutter guide (stylus)	183	040-183	1/4-20 Lockwasher
50	040-50	Carriage stop	184	040-184	1/4-20 Hex Nut
52	040-52	Socket hd. screw 8-32 x 1-1/2"	186	045-186	6-32 x 3/8" set screw
53	045-53A	Cutter guide binding washer	187	045-187	dowel
54	045-54	Cutter guide binding screw	188	045-188	dowel spring
55A	045-55A	Adjusting screw	189	045-189	Adjustment dial
56	040-56	Key gauge	190	045-190	Cutter guide label
57	024B-57	Key gauge bracket	194	045-194	#10 flat washer
58	024B-58	Key gauge dowel pin	195	045-195	10-32 x 1/2" Button hd. screw
59	025-59	Key gauge housing	198	045-198	7/16-14 x 3/4" set screw
60	025-60	Cap screw, 8-32 x 1/2"	199	045-199	1/2-20 x 1/2" set screw
61	025-61	Circuit Breaker, ETA 1658	IM	044HD-IM	Instruction manual
62A	025-62A	On/Off switch	NS	025-240	220V 1/4HP motor
65	044HD-65	Machined base			
68	040-68	Electrical cover			
70	040-70	Rubber mount			
74	040-74	Truss head screw, 8-32			
75	040-75	Motor, 1/4hp, 115V			

Operating Handles

The 044 HD key machine is shipped completely assembled except for the carriage handle and the lever handle. Upon unpacking the machine, locate the carriage handle and thread it into the carriage in the area directly above the trigger assembly. Then, cut the nylon band holding the carriage rigid and insert the lower end of the lever handle into the hole in the pinion shaft (located at the front of the machine on the left side). Tighten the set screw on the front of the pinion shaft to secure the lever handle. Refer to page 5 if unsure of handle placement.

Test keys

A series of cut keys are supplied with your machine. These keys were cut on your machine and represent the result of our quality inspectors' work before approving your machine for shipment. The keys are reproductions of factory dimensioned pattern keys and are accurate to .002" or less. Save these keys and use them as standards to check the accuracy of cuts in the keys you make. Duplicating a key and then using a key micrometer or caliper to compare the actual depth of the cuts on both the duplicate and the pattern key will allow you to see if your machine is cutting too deep or too shallow, thus indicating that an adjustment of the cutter guide is necessary.

Proper key cutting techniques

Even though your 044 HD key machine is designed to make key cutting fast, efficient and accurate, operator skill is important. The actual mechanics of placing keys within the vise jaws is simple to learn, but there are some basics that must be followed. A properly adjusted key machine used by someone who ignores good key cutting techniques will NOT produce a good key. The way a person clamps a key into the vise jaws is critical to the accuracy of the duplicated key.

Remember - the real purpose of a duplicate key is to operate the lock for which it was intended. If customers return keys, you should reexamine your cutting techniques and adjustment of the machine.

Here are some important operating tips:

1. Vise jaws - clean them regularly so that no metal chips lie under the keys. **It is essential that both keys lie flat across the entire width of each vise jaw. Neither key should be tilted.**
2. Do NOT use pliers or other tools to tighten the vise jaws. Firm hand pressure is sufficient.
3. Keep the carriage shaft free of metal chips. A thin film of oil can be applied to it. The carriage should be free to move without binding.
4. NEVER touch the shoulder of a key to the side of the cutter guide. This will cause the shoulder of the key blank to touch the side of the cutting wheel. When this happens, some of the metal will be cut away from the shoulder of the key blank. If the resulting duplicated key is duplicated two, three, four times over, an error will accumulate and cause a non-operating key. Do not grind away the shoulder.
5. Don't run the cutter into the vise jaw; this will dull the cutter, and reduce cutter efficiency.
6. Keep the cutter clean. Don't let any foreign objects or instruments blunt it. This cutter is a precise cutting tool and should be handled with care.
7. Lubrication requirements for your new "HD" Performance Series key machine are minimized through the use of sealed, permanently lubricated cutter spindle bearings. The carriage shaft however, should be inspected on a routine basis, and wiped with a dry, clean cloth to remove any chip buildup that occurs. After cleaning, application of a dry film lubricant is recommended for maximum service life; spray type lubricants that dry completely once applied are fine. Depending on usage, the machine's 1/4 hp motor may require lubrication once annually. Refer to the label on the motor for lubrication details and recommended interval.

HOW TO DUPLICATE KEYS

General key duplication procedures

WARNING: Do not install or remove keys unless the off/on switch is in the OFF position! Always wear eye protection when operating this machine!

There are four procedures that the machine operator performs to insure proper duplication of a key:

1. Selection of the proper key blank. Compare the head, length, and key blank's cross section (width, angle, and location of grooves) with the key to be duplicated to assure that a proper match has been made.
2. Ensuring both four-way vise jaws have been placed in the proper position for the type of key to be duplicated. See "Using the four-way vise jaws" section of this manual.
3. Proper alignment of the pattern key and blank key within the vise jaws. See "Aligning keys in the vise jaws".
4. Actual duplication of the pattern key; which can be properly accomplished only after the previous steps are performed.

Using the four-way vise jaws

Your 044 HD is equipped with the KABA ILCO versatile Four-way, Super Jaw 3 vise jaws. They feature four unique clamping surfaces to securely grip virtually any typical cylinder key (see Fig. 1).

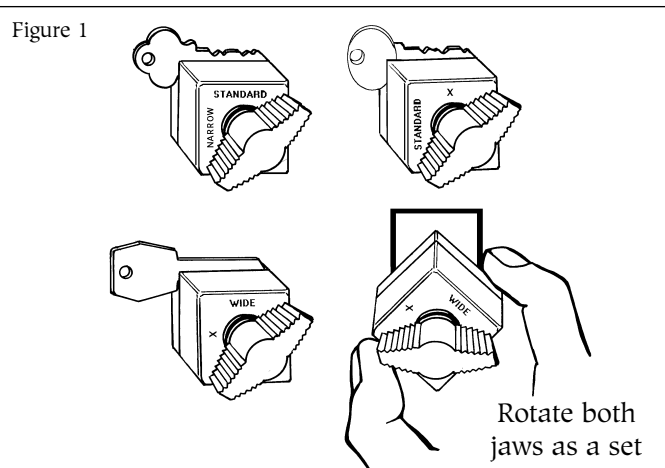

Using the four-way vise jaws (cont.)

To obtain the best gripping action possible, it is necessary to assure that the proper vise jaw position is selected for each key you duplicate. The vise positions are explained below and proper usage shown in figure 2.

Standard - for holding regular cylinder keys, such as house keys, single sided automotive keys, padlock keys, with one or two shoulders.

Narrow - for holding the 1092B and other narrow width keys.

Wide - for holding the Ford double-sided keys and similar types, either primary or secondary. When positioning the keys in the vise jaws, lay the key so that its center ledge is flat against the top surface of the jaw.

X - Ideal for holding most double-sided convenience keys used on most current automobiles. Grip these keys by the grooves rather than the blade edge where the cuts are located (see Fig. 2).

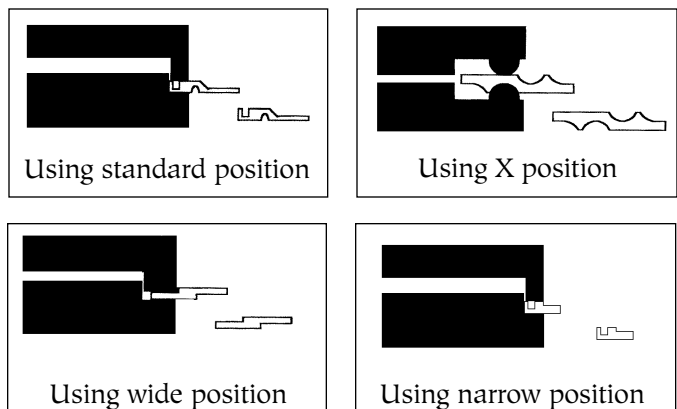
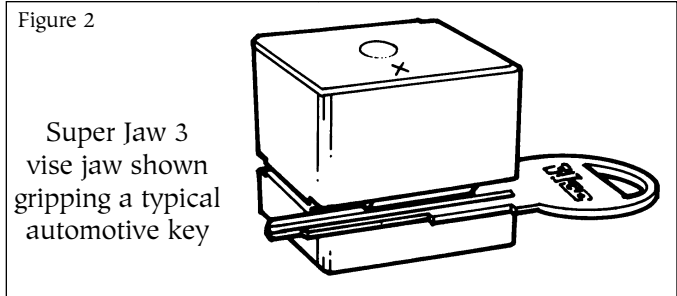

To reposition the vise jaws, as from Standard to Wide, first loosen the wing nuts. Then lift upward on the top and bottom of each vise jaw as a complete unit to raise them above their seat in the carriage. Rotate the jaws until the chosen vise position is facing toward the rear of the machine and lower the jaws back into contact with the carriage. Both left and right vise jaws should be rotated to the same position.

Aligning keys in the vise jaws Keys with shoulders

WARNING: Do not install or remove keys unless the off/on switch is in the off position.

Both the pattern key and the key blank must be properly aligned and securely clamped in the vise jaws prior to duplication. The correct procedure to do this follows.

1. Move the carriage lever to the left as far as possible (See Fig. 3).

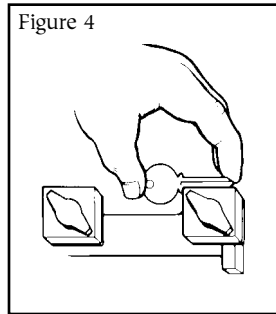
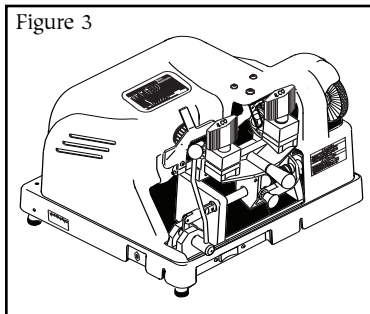

2. Assure that both vise jaws are rotated to the correct position for the type of key being duplicated.
3. Place the key blank in the right hand jaw. Position it so that it is parallel with the front portion of the jaw (see Fig. 4). Tighten wing nut lightly.
4. Swing key gauge down to rest on the blade of the key blank. Slowly move carriage lever clockwise to the right until the shoulder of the key blank butts up against the edge of the key gauge (See Fig. 5).
5. Use index finger to press down on the front edge of the key blank while loosening wing nut. Retighten securely after assuring that the key blank is contacting key gauge and is properly seated in the vise jaw.
6. Position pattern key in the left vise jaw repeating the procedure described in step 4.

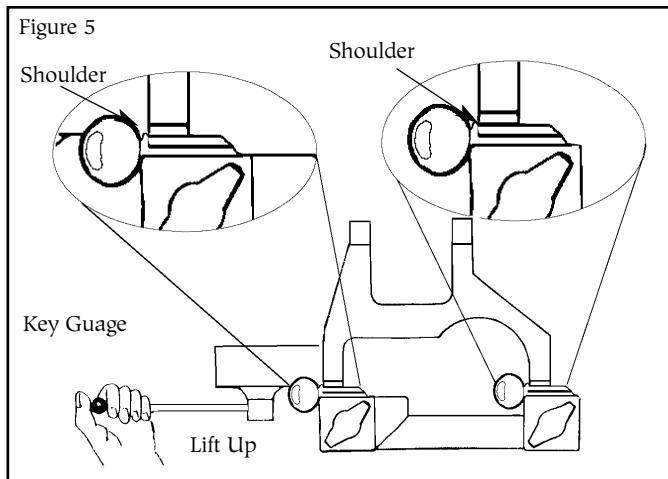

7. Check to ensure that the pattern key and blank key's shoulder are snug against the key gauge and both keys positioned level (not tilted) in the vise jaws. Return key gauge to the "up" position. The key is now properly aligned for duplication.

Aligning keys in the vise jaws Keys without Shoulders

On keys that don't have a conventional shoulder, such as the Ford double-sided key, the tip of the key is used as the aligning point. With keys of this type follow this procedure.

1. Assure that both vise jaws are rotated to the correct position for the type of key being duplicated.
2. Position the key blank in the right hand jaw. For most tip gauged automotive keys, position the blank so that the tip is roughly 1/4" left of the jaws right edge. Tighten the jaws wing nut securely.
3. Move the carriage lever to the left so that the key gauge's right hand "finger", **with gauge lowered**, is just forward of the key blank's tip.
4. Insert the customer's key (pattern key) in a similar manner in the left hand jaw. Then position both the customer's key and the key blank so that their tips are both in **direct contact** with the left edge of the key gauge fingers (See Fig. 6).

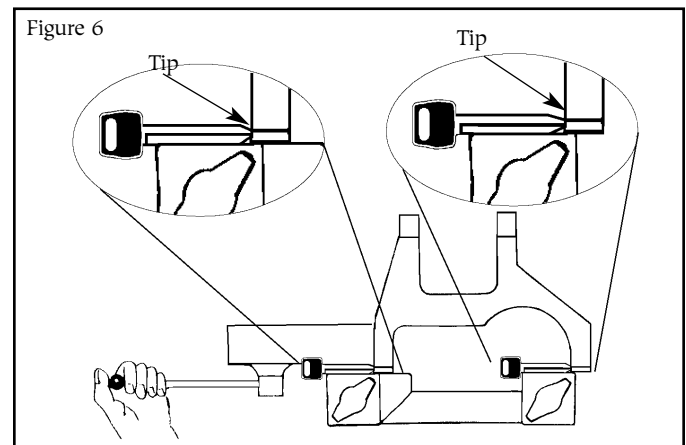

5. After both the customer's key and blank key are aligned, left key gauge to its raised position.
6. If a key is cut on both sides, after duplicating "side one" rotate and proceed with "side two" using the same alignment procedure. In the case of Ford keys as well as most double-sided European and Japanese double sided keys, only the blank needs to be rotated as the cuts are the same on both sides.
7. Refer to page 12 for additional information covering the actual key duplication process.

THE CUTTING OPERATION / REPLACING THE CUTTER

General Operating Sequence

WARNING: Do not install or remove keys unless the off/on switch is in the off position. Always wear eye protection when operating this machine.

1. Rotate both vise jaws to the station suitable for the key being duplicated.
2. Insert the blank key and pattern key into the vise jaws using the appropriate method described under "Aligning Keys in the Vise Jaws". Be sure that both keys are laying level in the vise jaws and are not tilted.
3. After the keys are aligned, move the carriage lever to the right (clockwise) until the cutter guide is slightly left of the cut closest to the head of the pattern key (see Fig. 7)
5. Press the off/on switch to the "on" position.
6. **Push down on the carriage handle while pulling out on the carriage trigger** (See Fig. 8).

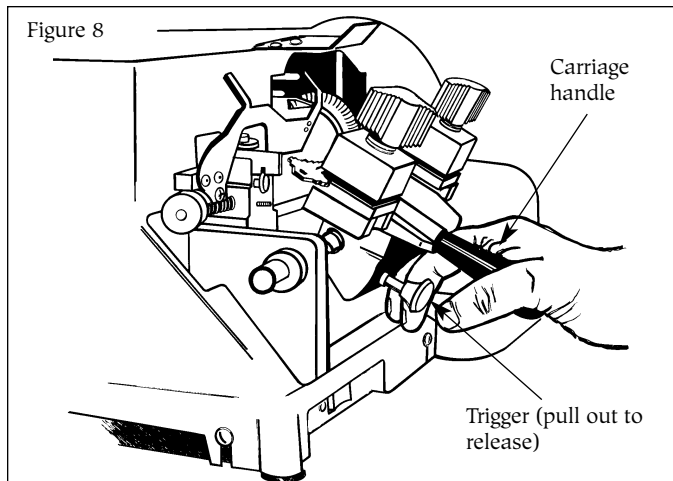
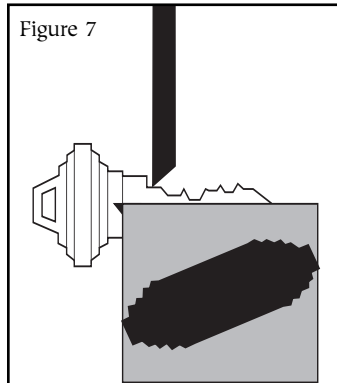

This will allow you to ease the carriage up into cutting position. Take care to ensure that the carriage does not "slam" forward as this will result in probable cutter damage. Remember, best results are obtained if the cutter guide makes initial contact slightly left of the cut closest to the head of the pattern key. Do not permit the cutter to touch the should of the key blank.

6. The carriage movement is controlled by the carriage lever. Using slow moderate speed, smoothly move the carriage lever to the left (counter clockwise). Avoid using an erratic, jerking movement! Once the cutter is at the tip of the key, move the carriage to the right by moving the carriage lever clockwise. This will result in a second cutting pass over the key blank. STOP before cutter contact with the shoulder of the blank occurs.
7. Press the off/on switch to the "off" position and remove finished key by pushing down on the carriage handle until the trigger clicks into place. Then loosen wing nut to remove duplicate key.
8. To deburr the key, turn the machine on, and position the cut key lightly against the rotating deburring brush.

Replacing the Cutter

The P-CU20 cutter used on this machine is .250 in diameter, .093" thick and has a $\frac{1}{8}$ " hole. It's a milling cutter, made out of high speed steel. It has a flat left side, which is excellent for making deep cuts, when these cuts are next to the shoulder, such as on GM, Chicago, etc. No warranty is placed on the cutter, operators should treat it with care and avoid harsh usage. Do not force the carriage up, causing the key blank to bang into the cutter, and do not apply heavy pressure when cutting. Also, do not let the cutter run into the vise jaw; this will dull the cutter quickly.

As with any metal cutting instrument, the P-CU20 will dull with usage. There are three ways to tell when a cutter is dull and requires replacing:

1. Time - a dull cutter takes longer to make the cuts.
2. Sound - a dull cutter will emit a shrill sound as it runs across the key blank.
3. Burrs - a dull cutter will not cut away the metal but will roll it away. When this occurs, there will be a buildup of metal burrs on the underside of the key. If this buildup is heavy, the cutter is dull. A sharp cutter leaves little or no burrs.

To replace the cutter, use two wrenches, one $\frac{3}{4}$ " wrench for the cutter nut and one $\frac{1}{2}$ " wrench for the cutter shaft. Set the two wrenches in position and loosen the cutter nut. Note that the cutter nut has a reverse thread and turns downward to loosen. Remove the spacer washers and the dull cutter. Install the new cutter, the washers, and the nut.

Adjusting for depth of cut

To ensure safety, UNPLUG machine from its power source before adjusting for depth of cut. It's imperative that the key guide and the cutter be in the same plane, that is, aligned to each other. If the cutter guide protrudes further than the cutter, the resulting cuts in a key blank will be too shallow and the duplicate key will not work. Likewise, if the cutter guide is behind the cutter, the cuts in the key will be too deep (see Fig. 9).

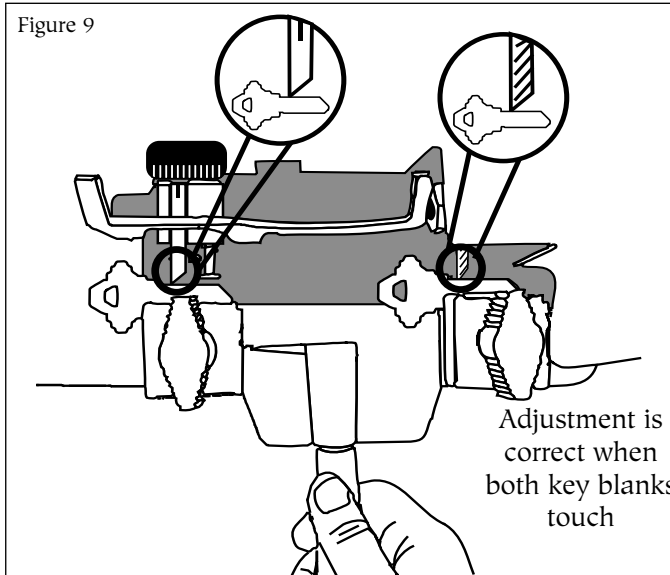

To check the depth adjustment, insert two identical key blanks into the vise jaws, setting them flat in each vise. (It is not necessary to align the blanks.) Then, raise the carriage, positioning the left blank against the cutter guide and the right blank against the cutter. Next, turn the machine pulley by hand and note the right key blank. The cutter should just barely graze the key blank when the adjustment is correct.

No cutter is perfectly round so make one complete rotation of the cutter before changing adjustment. There will

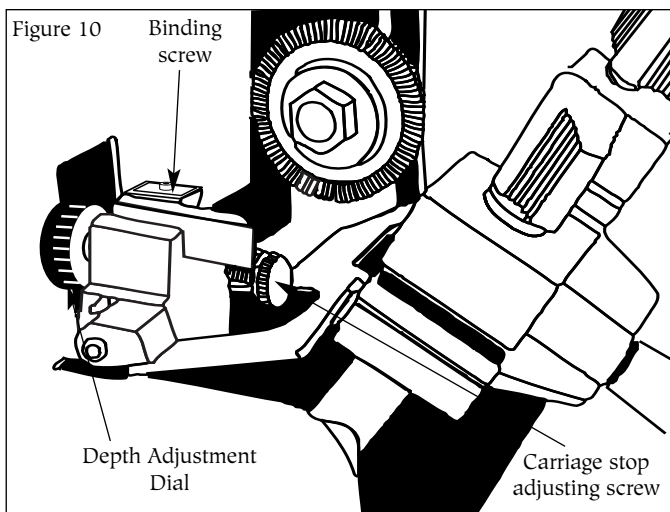

be a high point on the cutter; the adjustment should be made to the high point. If the cutter does not touch the key blank after one rotation, proceed to change the adjustment.

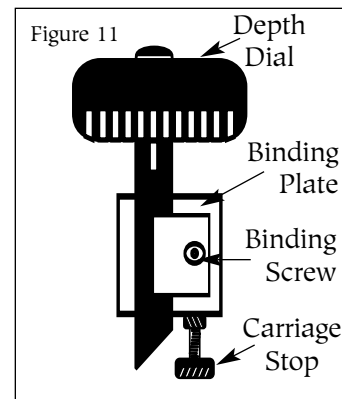

To adjust the cutter guide, loosen the binding screw on top of the cutter guide **slightly**. (see Fig. 10 & 11). Once you have loosened this screw, the depth adjustment dial can be rotated to the left (to decrease depth of cut) or to the right (to increase depth of cut). Again, proper adjustment will be achieved when the cutter

just **barely grazes** the key blank before it while the cutter guide is in contact with the other key blank. Retighten the binding screw once the calibration process is completed. Recheck after tightening to assure that adjustment did not shift.

Each calibration mark on the depth adjustment dial is equivalent to approx. .0015" (1 1/2 thousandths of an inch). As you can see, this system can allow for very precise adjustment of your new key machine. In fact, if you have a key micrometer or dial caliper available, you can adjust your machine with "factory accuracy". To do this, you would simply duplicate a key and measure cuts on both the "pattern key" and the duplicate key for comparison. This would show any deviation that existed and whether the duplicate cuts were too deep or too shallow and by how much. With this information, you can use the depth adjustment dial on your machine to calibrate your machine for best possible accuracy. This is very important as many locks are designed with close fit tolerances and the keys you duplicate are often themselves copies; functional but just barely so. The more accurate your key machine is adjusted, the closer your duplicates will match their originals, resulting in fewer non-functional miscuts!

It is very important to understand that adjusting your machine is not a "one time" procedure. As the cutter on your machine wears down, the machine must be adjusted to compensate. It is good shop practice to **check** you machines' depth adjustment every 2-4 weeks, based upon your store's key cutting volume and readjust as necessary. You will find that re-calibration is seldom needed, but by checking and correcting **BEFORE** customers begin returning miscut keys, you will create a reputation for your store as a "good place" to have keys duplicated.

ADJUSTMENTS

Adjusting for spacing

There is no adjustment for spacing. However, if a key gauge assembly is ever replaced, the key gauge must be fitted to the machine after it has been installed. To do this, first install a pattern key and key blank and align these against the cutter guide and cutter. Then lower the key gauge and file the appropriate finger of the gauge to allow contact with the shoulder of both keys.

Adjust the Carriage Stop

The purpose of the carriage stop is to prevent the cutter from hitting into the right vise jaw. The stop is a nut and bolt and is adjustable. To check the adjustment, raise carriage (without keys in vise jaws) and rotate the cutter by hand. The cutter should not contact the vise jaw. When the carriage stop is properly adjusted, there should be a space of .008" between the vise jaw and the cutter (this is about the thickness of an ordinary business card). Do not allow a greater distance since this may affect the depth of cut.

Cleaning

Your machine should be kept clean of all filings and dust. The most critical areas are the carriage jaws and shafts. A one inch paint brush is ideal to brush these areas of the machine. The shafts should be wiped periodically with a lightly oiled cloth. We suggest brushing the jaws often as even a single filing can alter the accuracy of the machine.



A Member of the Kaba Group

Kaba Ilco Corp.

P O Box 2627 (27802)

400 Jeffreys Rd., Rocky Mount, NC 27804

Tel.: (252) 446-3321 • Fax: (252) 446-4702

www.kaba-ilco.com